



Cabinet Mount System Description (CNG):

50 - 70 DGE

Type III or IV Cylinders

Powder coated Aluminum protective covers

Powder coated Steel cylinder frame with front crash impact protection

All structural and plumbing components designed as per NFPA 52 – 2006 edition

Stainless Steel Fuel Lines

Stainless Steel Vent Lines

High Pressure Check Valve

Fuel Management Panel including;

High Pressure Gauge before pressure regulator

Low Pressure Gauge after pressure regulator

NGV1 3600 psi receptacle with dust cap

ITT High Pressure Regulator

High Pressure Coalescing Filter

Pressure Transducer / Dash mounted electronic fuel gage

Optional Equipment:

- Auxillary left, right or front bumper fill port
- Ignition kill cap(s)
- Am-Gads Methane Detection System
- 20 year life tanks (15 year standard)
- NGV-2 or FMVSS-304 approval
- Full-length cabinet access doors

IF IN DOUBT-ASK

Specifications:

Approximate system dry weight: 1440 LBS

Approximate system weight CNG full: 1768 LBS

Tank Specs.

15.9 O.D. X 71.0 LG.

Tank Volume (SCF) standard cubic feet) each: 1791 SCF

Tank volume (DGE) diesel gallon equivalent) each: 12.9 DGE

Total System Volume : 7164 SCF / 51.6 DGE

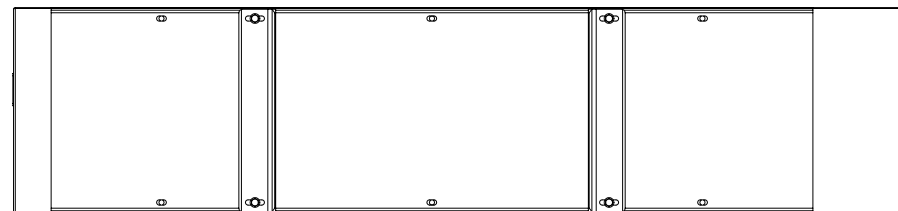
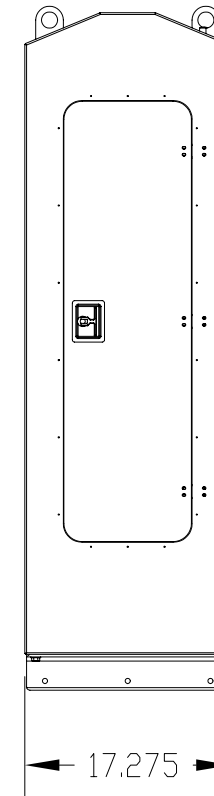
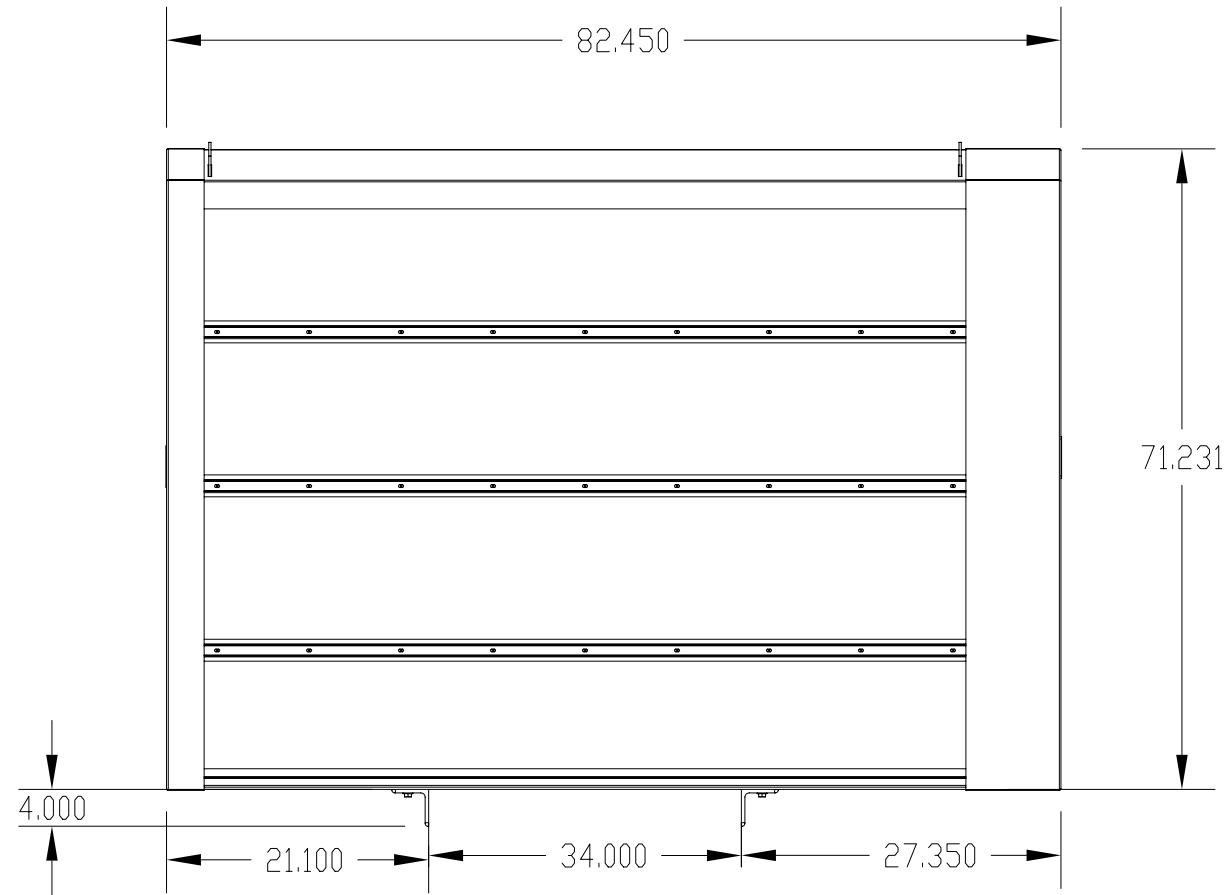
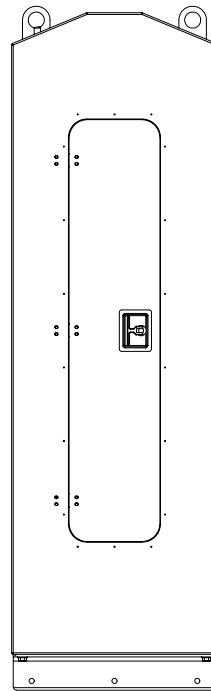

QTY		PART NO.	4TCNGTCM-10000	
		MATERIAL		
		COMPLETION DATE:	06-Apr-05	
		FAB INDUSTRIES LLC		
		ANNISTON, ALABAMA USA		
		CUSTOMER:		
REV #	BY	DATE	DESCRIPTION/REASON	
			REFERENCE DRAWING:	
<small>This drawing and the designs depicted therein are the property of FAB Industries LLC. Company of Anniston Alabama, and we are covered by issued and/or pending U.S. and Foreign patents. This material is provided to you subject to the condition that it shall not be reproduced, copied, disclosed to other vendors or manufacturers of similar articles, lent or otherwise disposed of, directly or indirectly. It shall not be used to furnish any information for the making of drawings, prints or apparatus, or parts therefore, except where otherwise specifically provided for by contract with FAB Industries, LLC.</small>				
		DRAWN:	Don Burney	SCALE: 0.050
		CHECKED:		SHEET: 1 of 1
		APPROVED:		DWG NO. 4TCNGTCM-10000

IF IN DOUBT-ASK

Specifications:

Approximate system dry weight: 1832 LBS

Approximate system weight CNG full: 2281 LBS

Tank Specs.

21.0 O.D. X 80.0 LG.

Tank Volume (SCF) standard cubic feet) each: 3267 SCF

Tank volume (DGE) diesel gallon equivalent) each: 23.5 DGE

Total System Volume : 9801 SCF / 70.5 DGE

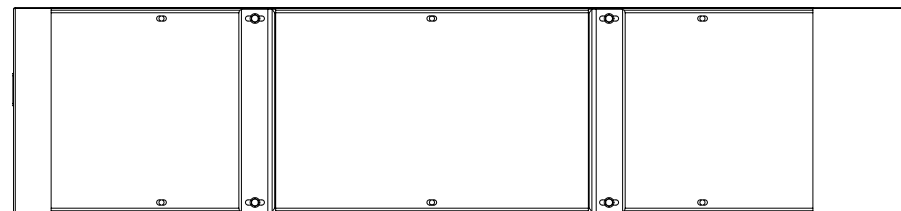
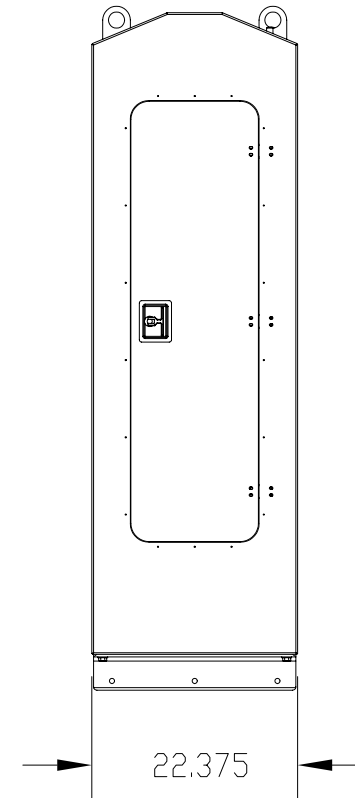
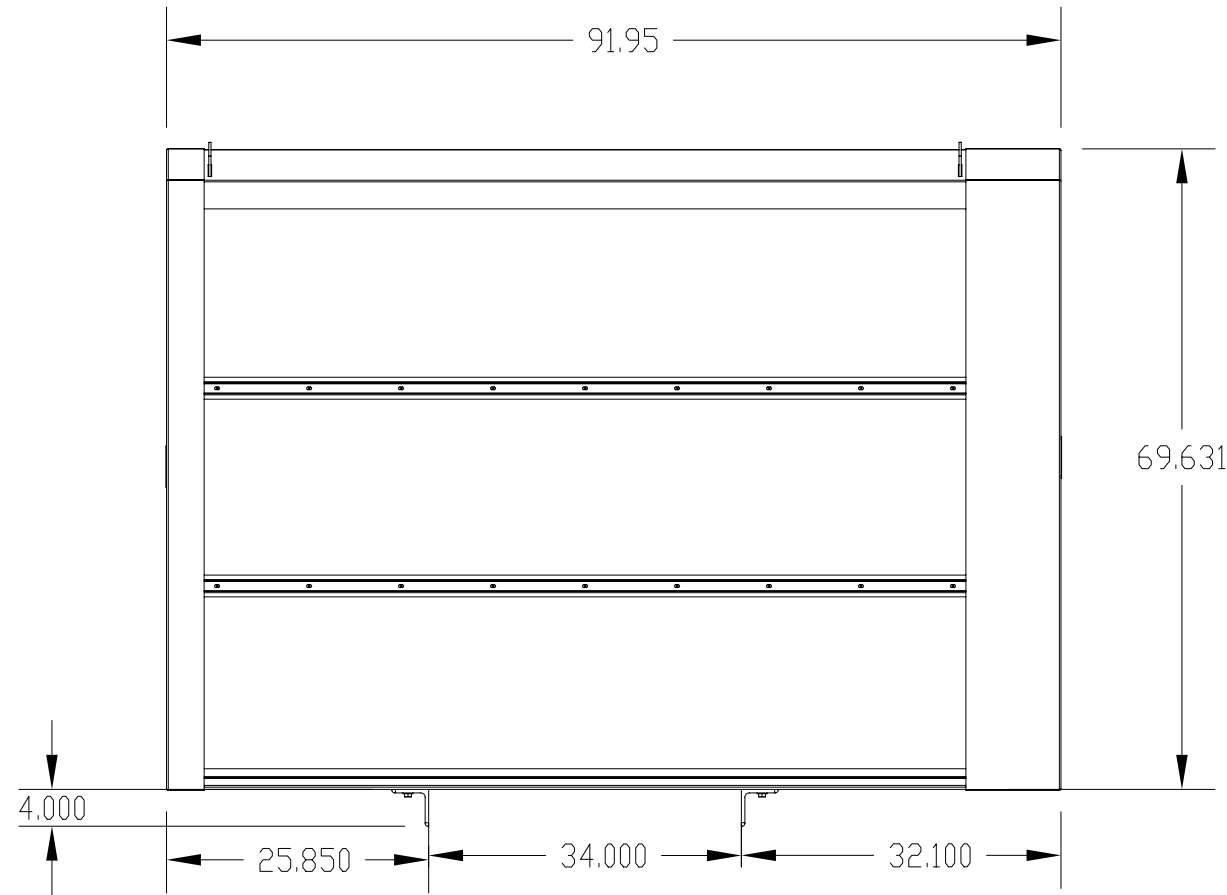
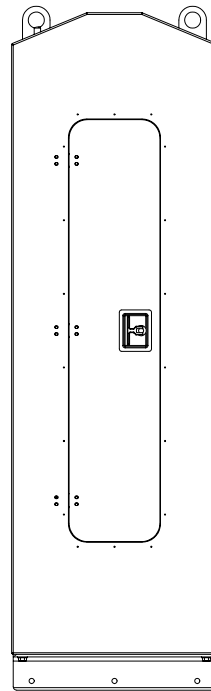

QTY		PART NO.	3TCNGTCM-10000-SCH	
		MATERIAL		
		COMPLETION DATE:	06-Apr-05	
		FAB INDUSTRIES LLC		
		ANNISTON, ALABAMA USA		
		CUSTOMER:		
REV #	BY	DATE	DESCRIPTION/REASON	
			REFERENCE DRAWING:	
<small>This drawing and the designs depicted therein are the property of FAB Industries LLC. Company of Anniston Alabama, and we are covered by issued and/or pending U.S. and Foreign patents. This material is provided to you subject to the condition that it shall not be reproduced, copied, disclosed to other vendors or manufacturers of similar articles, lent or otherwise disposed of, directly or indirectly. It shall not be used to furnish any information for the making of drawings, prints or apparatus, or parts therefore, except where otherwise specifically provided for by contract with FAB Industries, LLC.</small>				
			DESCRIPTION:	3 TANK TRUCK CHASSIS MOUNTED(BEHIND CAB) CNG SYSTEM
		DRAWN: Don Burney	SCALE: 0.050	SHEET: 1 of 1
		CHECKED:	DWG NO.	
		APPROVED:	3TCNGTCM-10000-SCH	